



INDEXDESIGNS

Rotary Table Manufacturer

User and Maintenance Manual

Fanuc CNC

VH-5C

VH-6

VH-8

VH-11

VH-15

TR-6 Tilt Rotary

TR-8 Tilt Rotary

2023

**Index Designs LLC
21720 Marilla St.
Chatsworth, CA 91311
www.IndexDesignsCNC.com**

Table of Contents

Introduction.....	3
Rotary table setup.....	4
Backlash Adjustment.....	5
Oil Fill Procedures.....	6
Zero Return (Homing) Switch.....	7
Limit Switches and Hard Stop (TR-8 only).....	8-9
Diagrams (Fanuc).....	10-12

Introduction

Rotary Table	Brake	Ratio	Oil Type	Mounting Orientation	Air Collect Option
VH-5C	N/A	60 to 1	Mobil SHC 634 or equivalent	Vertical or Horizontal	Locking Air 100-120 PSI
VH-6 VH-8 VH-11 VH-15 TR-6 TR-8	M60/M61, Air use approximately 100-120 PSI	90 to 1	Mobil SHC 634 or equivalent	Vertical or Horizontal	Locking Air 100-120 PSI

Rotary Table Maintenance

Air

When using air with the rotary table, be sure that the air is clean and dry before reaching the rotary table components. If the air is not clean and dry it can cause the brake to seize.

Oil

Use Mobil SHC 634 or equivalent gear oil. Change oil only when needed. Typical use of rotary will require an oil change every 5 years. Fill till covers gear. If table has no sight glass, open the oil fill hole, add oil till over gear. When oil settles, use a scale as a dip stick to see that 0.1” of oil covers the gear.

Connectors

Keep the cables and connectors free of oil and chips. When not in use, protect the connectors from the elements, chips and the housings from getting bent and misshaped.

Avoid Rust

Use a light coat of oil on all rotary table surfaces to prevent rust.

Rotary Table Setup

Positioning Rotary onto machine's table

1. Move the machine's table all the way forward to allow for better access to loading the rotary onto the machine's table.
2. Wipe clean with a light oil the vertical or horizontal surface that will be mounted to the machine's table.
3. Attach table keys if desired to the surface that will mount to the machine's table.
4. User proper lifting procedures to put rotary onto machine's table.
5. Prepare and insert T-nuts or T-bolts into the T-slot before putting the rotary onto the table.
6. Position the table on the right side of the machine's table over T-slots that position with the rotary tables mounting lip or notch.
7. Take note of the full travel of the machine, make sure the rotary does not hit the Z ways or the door when the machine moves it full travel.
8. Take note of the cable and air lines coming from the rotary when the machine moves it's full travel.
9. Connect spring to hold cables and air lines out of machining area and chip tray, see Figure 6.

Operating the Brake (if present)

1. Check the CNC parameters to determine which M codes are used to operate the brake.
2. Use the M# command in Automatic or MDI mode to verify the brake is energized when the M command is executed.
3. Approximately 100 PSI of compressed air is required to operate the air brake.
4. When the air solenoid actuates there should be a audible sound initially, but there should not be leaking air.
5. Use the M# (brake off) command in Automatic or MDI mode to verify the brake disengages when the M# code command is executed.
6. Air will exhaust out the air valve when the M# command is executed to releases the brake.

Air Brake

The brake is actuated by clean and dry air which needs to be 100 psi minimum, the preferred pressure is 120 psi. There are no unclamp or clamp outputs on the brakes. When the state of the brake is changed, the CNC must wait approximately 1 second for the brake to release before motion continues.

Backlash Adjustment

1. Different models will have different screws and plates
2. Remove cover to expose end of worm opposite motor by removing screws a, b, c, and d, see figure 1.
3. Completely loosen screws 1, 2 & 4.
4. Loosen 3 & 5 just till the mount can be moved but it is still held in place.
5. Place indicator on the shaft to monitor movement, figure 2..
6. With screw driver lift the aluminum support plate till it raises the worm shaft 0.001". This will reduce backlash. **(IMPORTANT : Do not apply excessive force when adjusting the worm or else you might risk over adjusting and making your worm misaligned or too tight.)**
7. Tighten screws 1, 2, 3, 4 & 5, recheck backlash till backlash on the T-slots is just less than 0.0007"
8. Repeat steps 2 to 6 till the backlash desired is achieved.
9. Install worm gear cover and tighten screws a, b, c & d.

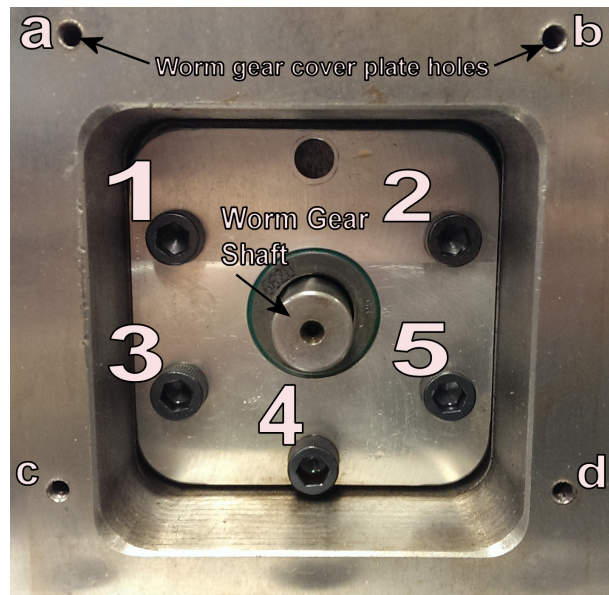

Figure 1: Holes a, b, c, & d cover the worm gear shaft. Screws 1, 2, 3, 4 & 5 hold worm gear shaft in place.

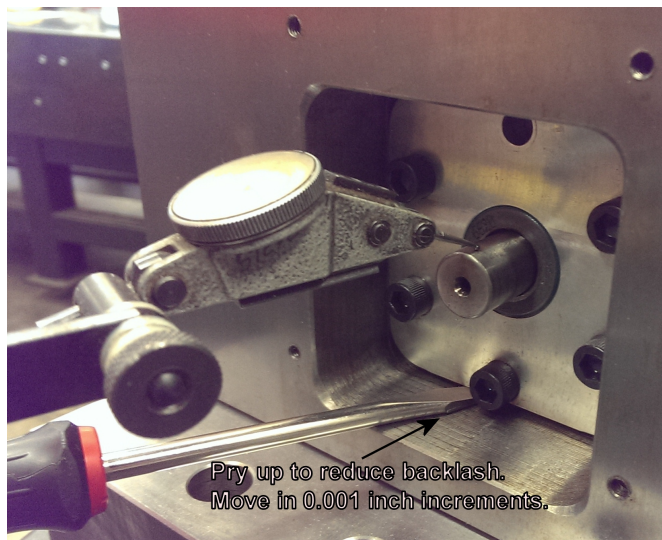

Figure 3: Pry up on bearing mount to reduce backlash, move in 0.001" increments, tighten, retest backlash at rotary table face.

Oil Fill procedure

1. Remove oil fill plug.
2. Add oil until oil covers the spindle housing (the bronze gear is mounted to this).
3. Use scale as a dip stick to verify about 0.1" of oil covers the housing.
4. Install oil fill plug.

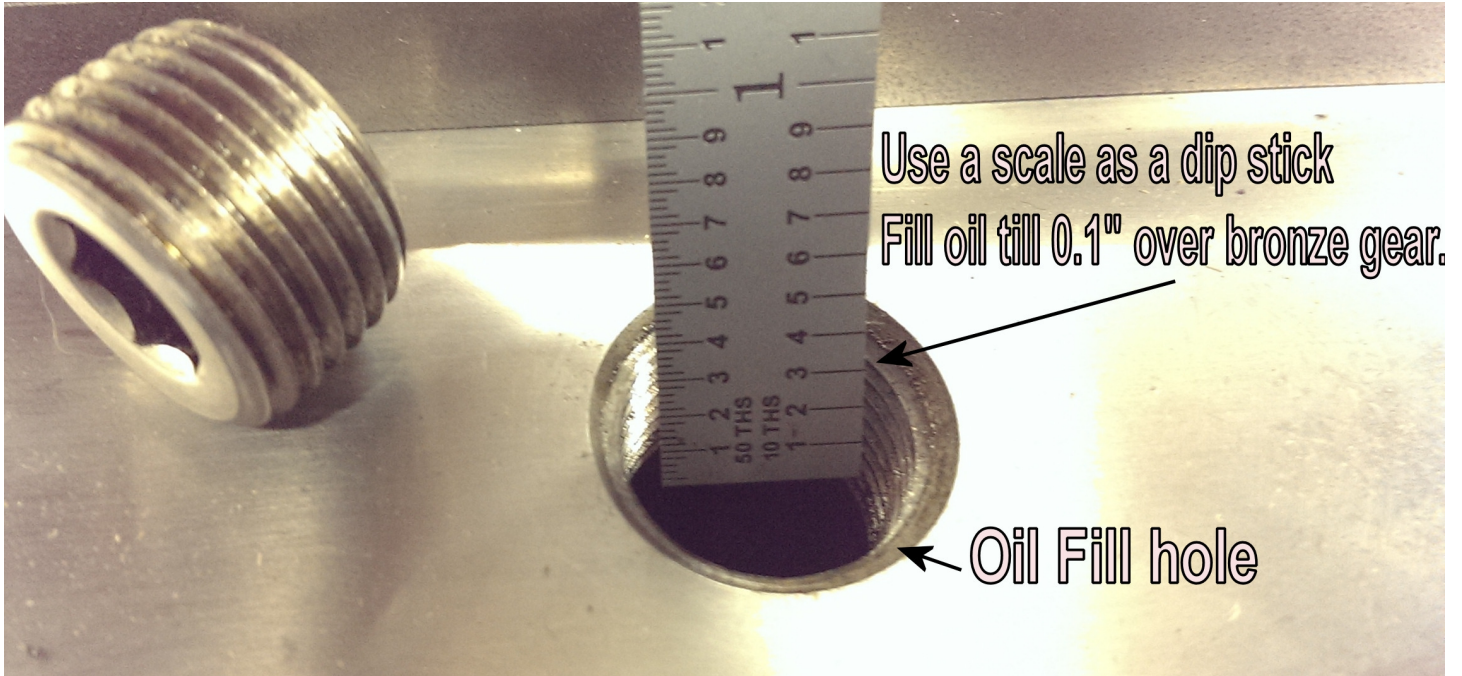

Figure 4: Oil fill, cover gear with 0.1 inch of oil.

Zero Return (Homing) Switch, see figure 3

Issue a “Zero Return” command from the CNC control. The control will rotate till the zero return proximity switch is triggered. Measure the distance to the desired zero position physically on the the table, whether this is when the T-slots are flat or the table is flat. Enter this measured distance into the zero return grid shift amount of the CNC as a correction value.

Repeat the zeroing procedure of the CNC, if the rotary axis is not at the desired corrected zero position, then repeat the grid shift adjustment until satisfied.

Typical Fanuc procedure:

1. Issue zero return
2. Select "MDI" mode
3. Press the function key “OFFSET SETTING”
4. Press the soft key “SETTING”.
5. Move the cursor to “PARAMETER WRITE” . May need to page up or down to get to the top of the Parameter numbers.
6. Turn on PWE (Parameter Write) make it a 1
7. Press the function Hard key "SYSTEM"
8. Press the softkey "PARAM"
9. Type 1815 and press "No.Search" . This should bring up parameter 1815.
10. Arrow down to axis to change
11. Change bit 4 (APZ). This will delete the current reference zero. Alarm must power down will appear, DO NOT POWER OFF
12. Go back to the parameter 1815 and make bit 4 a one
13. Power off machine for one minute and power up. New home position will be set.
14. Check coordinates, if they are off if they are not correct repeat steps.

Limit switches (TR-8 only)

Only the TR-8 will have limit switches installed.

The limit switches are normally open switches. Typically the CNC will use +24VDC to the common side of the switch. When a limit switch is closed by the limit trigger block, the limit input on the CNC will go high. There is a +Limit switch and a -Limit switch, see figure 3.

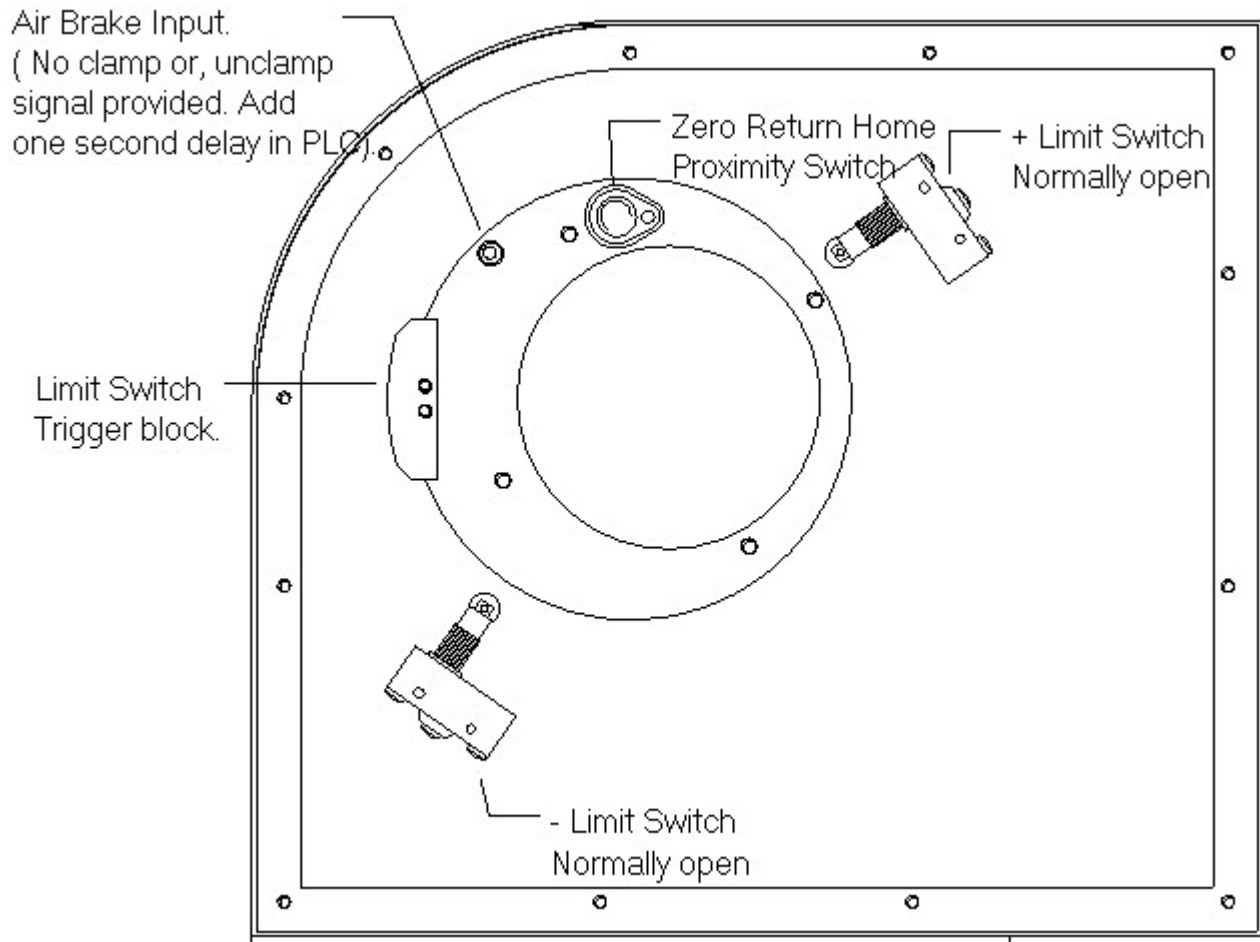

Figure 5: Limit switches, Zero switch and air brake input for Tilt tables.

Hard Limit Stop (if present)

Typically the tilt rotary tables have hard limits installed on the tilting axis. This hard stop will physically stop the table from tilting past the limit. When the table is stopped at the limit, it might not be able to move off this hard stop. The hard stop cover can be removed so the hard stop peg plate can be lifted out. The table can then be rotated into a safe area and the hard stop peg placed back into the table. Put the hard stop cover back over the hard limit, make sure that **gasket sealant** is put on the cover to prevent coolant from entering the table.



Illustration 1: Hard stop cover. Remove only if table can't be rotated off the hard stop.

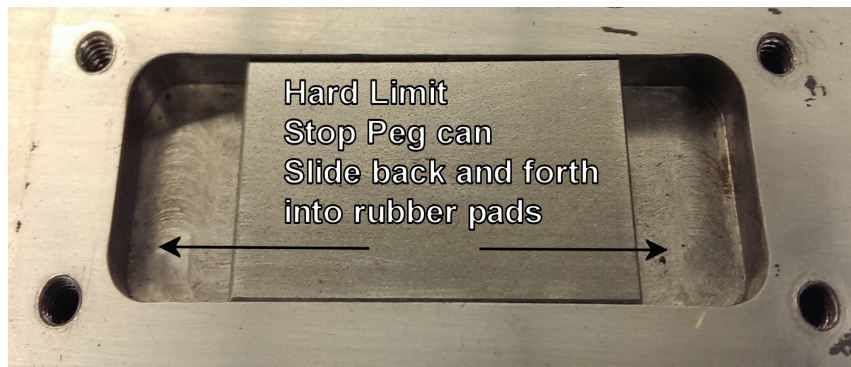

Illustration 2: The hard stop installed.

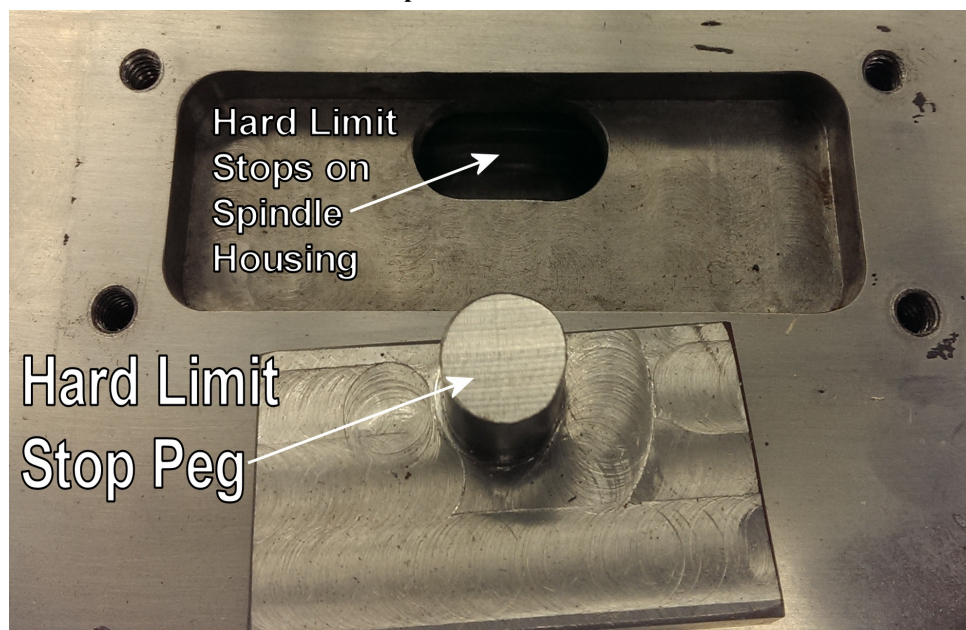
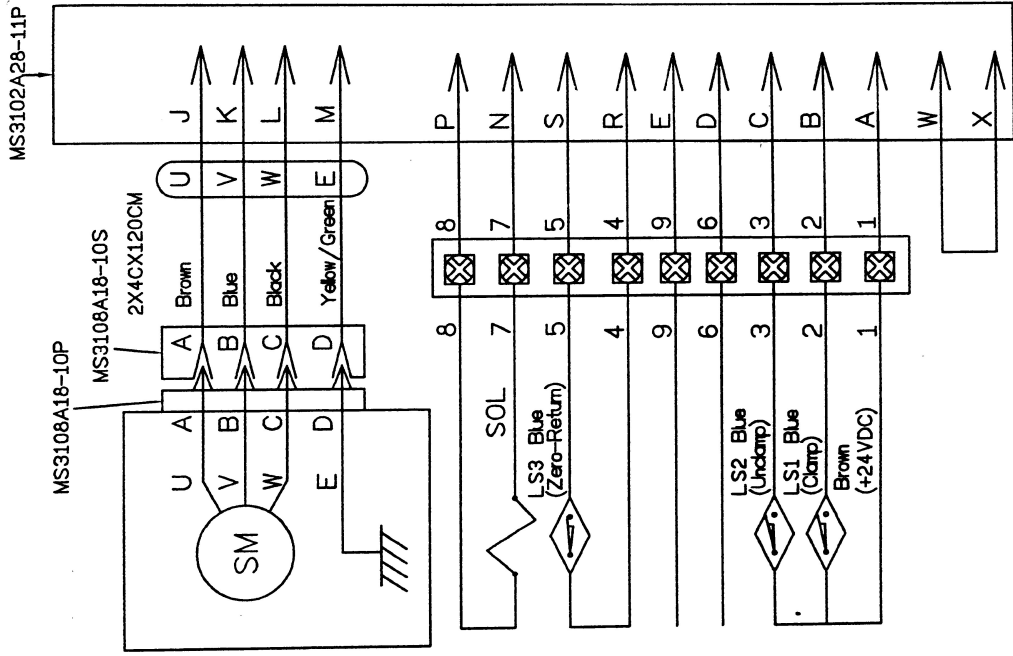
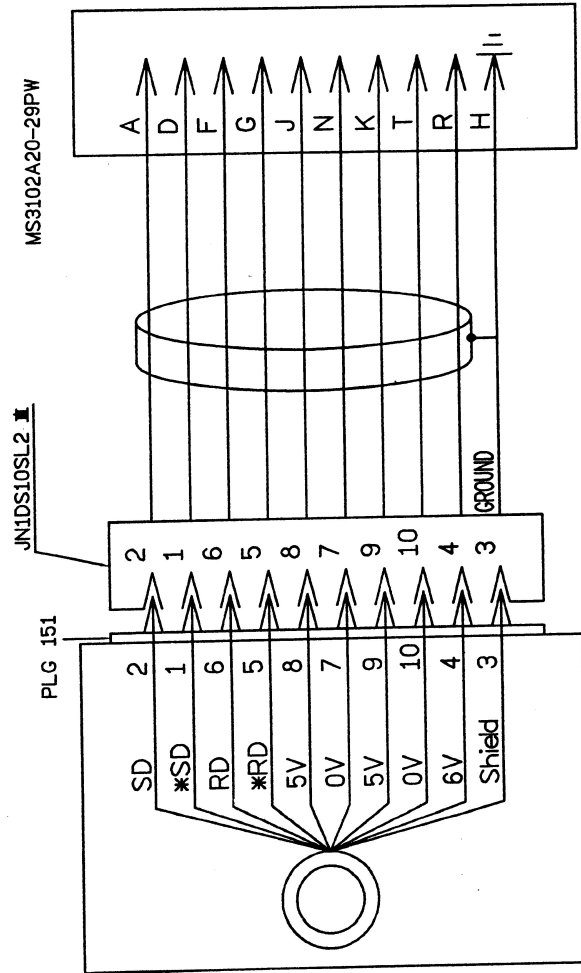

Illustration 3: Hard stop removed so table can rotate off hard stop. Make sure cover is sealed with gasket sealant when cover is put back on.

4i/α 8i/β 8is/β 12is/α 8is/α 12is

DETECTOR



$\alpha 4i / \alpha 8i / \beta 8is / \beta 12is / \alpha 8is / \alpha 12is$

DETECTOR

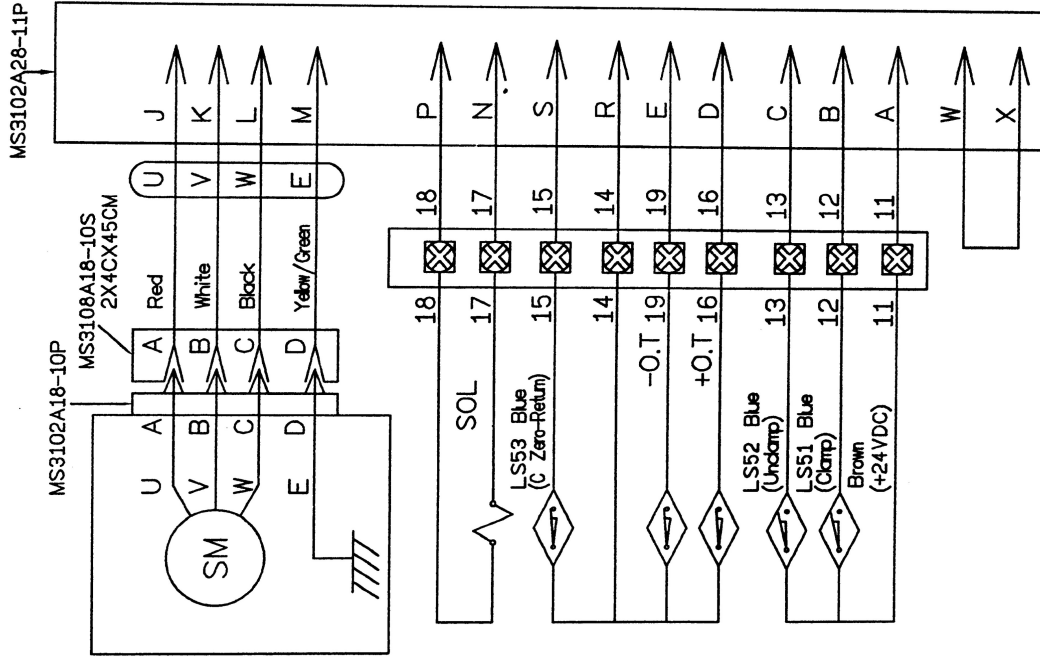
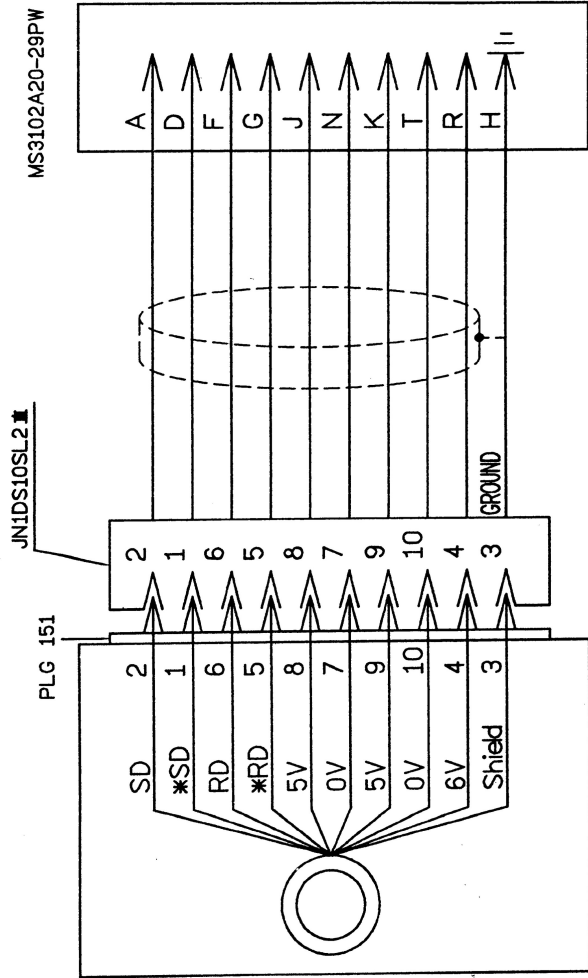

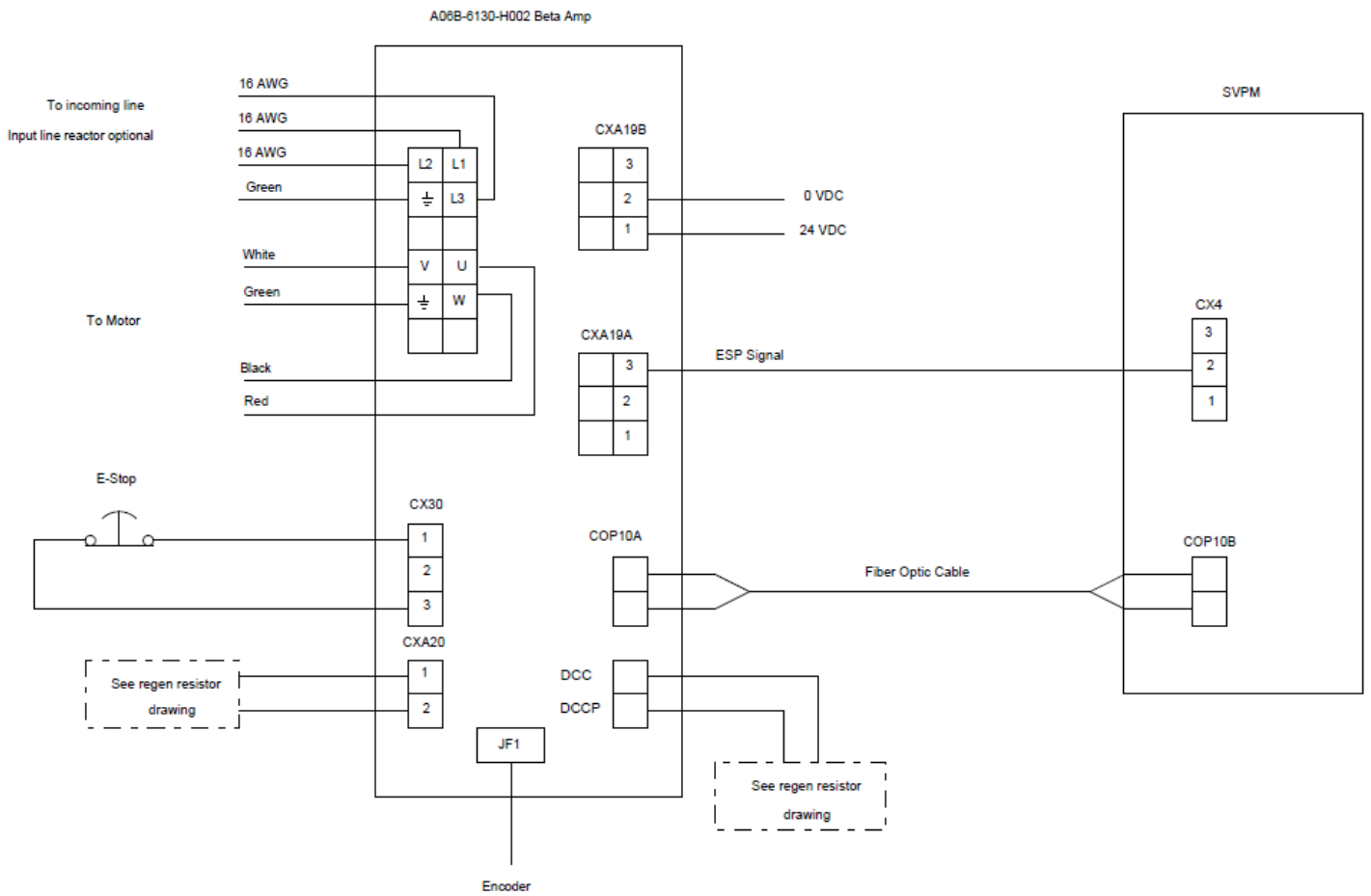

Figure 6: Typical Beta amplifier connections